



ARTESIAN SPAS®
Island Spas



OWNER'S MANUAL

Notes:

Island Spas



ARTESIAN SPAS

WWW.ARTESIANSPPAS.COM

Part # 11-0107-11 R0112

This manual covers the following spas

Grand Bahama



Grand Cayman



Antigua



Nevis



Captiva



Santa Cruz



Bimini



Dominica



St. Bart's



Copyright 2012 May Mfg. LLC - All rights Reserved. This document may not be copied, photocopied, reproduced, translated or transmitted in any form or for any purposes without the express written consent of Artesian Spas.

Table of Contents

Congratulations	1
Important Safety Instructions	3
Electrical Requirements and Installation	8
60Hz GFCI Wiring Schematic.....	9
50Hz Electrical Service Configuration Options..	11
Spa Start Up	16
Selecting a Location.....	16
Inspection.....	17
Filling the Spa with Water.....	17
Turning the Power On.....	18
Verifying Water Circulation.....	18
Testing the GFCI Breaker.....	19
Turning on the Spa for the first time.....	20
Priming the Pump.....	20
Water Preparation.....	20
Topside Controller Instructions	21
Initial Start up.....	21
Setting the Time of Day.....	21
Light.....	22
Mode.....	22
Jets.....	22
Preset Filter Cycles.....	23
Optional Filter Cycles.....	23
Temperature Set.....	24
Freeze Protection.....	25
ML700 Quick Reference Guide	25
Initial Startup.....	25
Time.....	25
Setting the Time.....	26
Standard Mode.....	26
Economy Mode.....	26
Sleep Mode.....	27
Standby Mode.....	27
Locking the Panel.....	27
Locking the Set Temperature.....	27
Additional Features.....	27

Table of Contents

Diagnostic Messages	28
Maintaining Your Spa	30
Draining Your Spa.....	30
Pillow Care.....	30
Jet Care.....	31
Removing, Installing, and Cleaning Filters.....	32
Winterizing Your Spa.....	33
Replacing the Light Bulb.....	33
Spa Cabinet Care.....	34
Cleaning Your Spa Interior.....	34
Cover Care.....	35
Chemical Treatment of Water.....	36
Water Chemistry	37
Water Treatment Glossary.....	37
Spa Chemicals Glossary.....	42
Maintaining the Proper pH.....	44
Warranty Information	45
Interior Spa Diagram	51

Congratulations!

Congratulations on the purchase of your new Island spa by Artesian. We know you will enjoy your spa. Although spas are relaxing and fun, we believe they can be an indispensable part of a healthy lifestyle. The spa lifestyle is one that encourages health and well-being.

Owning a spa brings some responsibility. With proper care, your spa will provide years of enjoyment and therapy for your family and friends. Please take time to read and understand all of the instructions provided before you install your Artesian spa. This owner's manual is meant to be a supplement to the training you should receive from your dealer when you purchase and start up your spa for the first time.

Please remember your spa is a powerful piece of electrical equipment. It is extremely important that you have it properly installed to ensure safe use. This manual explains safety precautions, installation instructions, and operating and maintenance procedures. If you have any questions regarding this manual, please call your competent Artesian spa dealer, who will be happy to further assist you.

**Make sure you
visit our website at www.artesianspas.com
and register your new Artesian spa.**

For your future reference and convenience, please record the Serial and Model number along with the installation date in the spaces provided below. **STORE THIS MANUAL WHERE YOU CAN EASILY FIND IT WHEN NEEDED.** The serial and model numbers are mounted on the base of the equipment enclosure area, as shown below.

Spa Serial Number _____

Spa Model Number _____

Spa Installation Date _____

Dealer Name, Address, and Telephone Number

Diagram of Where to Find Serial Number



Serial Number Information

Important Safety Warnings

PLEASE TAKE THE TIME TO READ ALL OF THESE WARNINGS AND CAUTIONS PRIOR TO USING YOUR SPA.

PLEASE, be a responsible spa owner. When installing and using this spa, always adhere to basic safety precautions. Be sure to list emergency telephone numbers at the telephone nearest the spa, including physician, hospital, ambulance, police and the fire department. Be certain to explain safety precautions to all new or occasional users of your spa. Remember, they may not be aware of the possible risks associated with the spa water temperature. Have at least one family member learn CPR (cardiopulmonary resuscitation). **IT COULD SAVE A LIFE!**

1. **READ AND FOLLOW ALL INSTRUCTIONS!**

2. **WARNING** - To reduce the risk of injury, do not permit children to use this product unless they are closely supervised at all times.

3. A wire connector is provided on this unit to connect a minimum 8 AWG (8.4 mm) solid copper conductor between this unit and any metal equipment, metal enclosures of electrical equipment, metal water pipe, or conduit within 5 feet (1.5 m) of the unit.

4. For cord connected/convertible units. **DANGER - Risk of Injury**

a) Replace damaged cord immediately.

b) Do not bury cord

c) Connect to a grounded, grounding type receptacle only.

5. **DANGER - Risk of Accidental Drowning** - Extreme caution must be exercised to prevent unauthorized access by children. To avoid accidents, ensure that children cannot use this spa unless they are supervised at all times.

6. **DANGER - Risk of Injury** - The suction fittings in this area are sized to match the specific water flow created by the pump. Should the need arise to replace the suction fittings or the pump, be sure the flow rates are compatible.

Never operate spa if the suction fittings are broken or missing. Never replace a suction fitting with one rated less than the flow rate marked on the original suction fitting.

7. **DANGER - Risk of Electrical Shock** - Install at least 5 feet (1.5 m) from all metal surfaces. As an alternative, a spa may be within 5 feet of metal surfaces if each metal surface is permanently connected by a minimum 8 AWG (8.4 mm) solid copper conductor to the wire connector on the terminal box that is provided for this purpose.

Important Safety Instructions

8. **DANGER - Risk of Electric Shock** - Do not permit any electrical appliance such as a light, telephone, radio, or television, within 5 feet (1.5 m) of a spa.

9. **WARNING - To reduce the risk of injury:**

a) The water in a spa should never exceed 40°C (104°F). Water temperatures between 38°C (100°F) and 40°C are considered safe for a healthy adult. Lower water temperatures are recommended for young children and when spa use exceeds 10 minutes.

b) Since excessive water temperatures have a high potential for causing fetal damage during the early months of pregnancy, pregnant or possibly pregnant women should limit spa water temperatures to 38°C (100°F).

c) Before entering a spa, the user should measure the water temperature with an accurate thermometer since the tolerance of water temperature regulating devices varies.

d) The use of alcohol, drugs, or medication before or during spa use may lead to unconsciousness with the possibility of drowning.

e) Obese persons and persons with a history of heart disease, low or high blood pressure, circulatory system problems, or diabetes should consult a physician before using a spa.

f) Persons using medication should consult a physician before using a spa since some medication may induce drowsiness while other medication may affect heart rate, blood pressure and circulation.

Save These Instructions

Equipment Assemblies

An equipment assembly shall be additionally provided with the following important safety instructions

1. **WARNING** - Risk of accidental drowning. Extreme caution must be exercised to prevent unauthorized access by children. To avoid accidents, ensure that children cannot use a spa or hot tub unless they are closely supervised at all times.

2. **DANGER** - To reduce the risk of drowning from hair and body entrapment, install a suction fitting(s) with a marked flow rate that equals or exceeds the flow rate marked on the equipment assembly.

3. **DANGER** - To reduce the risk of injury, do not remove the suction fittings. Never operate a spa or hot tub if the suction fittings are broken or missing. Never replace a suction fitting with one rated less than the flow rate marked on the equipment assembly.

Important Safety Instructions

4. **DANGER**- Risk of Electric Shock. Do not permit any electric appliance, such as a light, telephone, radio, or television, within 5 feet (1.5m) of a spa or hot tub.

5. **WARNING** - Risk of Electric Shock. Install at least 5 feet (1.5m) from inside wall of hot tub or spa using non metallic plumbing.

6. **WARNING** - To reduce the risk of injury:

a) The water in a spa should never exceed 40°C (104°F) Water temperatures between 38°C (100°F) and 40°C are considered safe for a healthy adult. Lower water temperatures are recommended for young children and when spa use exceeds 10 minutes.

b) Since excessive water temperatures have a high potential for causing fetal damage during the early months of pregnancy, pregnant or possibly pregnant women should limit spa water temperatures to 38°C (100°F).

c) Before entering a spa or hot tub, the user should measure the water temperature since the tolerance of water temperature regulating devices varies.

d) The use of alcohol, drugs or medication before or during spa or hot tub use may lead to unconsciousness with the possibility of drowning.

e) Obese persons and persons with a history of heart disease, low or high blood pressure, circulatory system problems, or diabetes should consult a physician before using a spa.

f) Persons using medication should consult a physician before using a spa or hot tub since some medication may induce drowsiness while other

7. For equipment assemblies with a gas heater

WARNING - Risk of suffocation. This equipment assembly uses a gas heater and is intended for outdoor use only unless proper ventilation can be provided for an indoor installation.

8. For equipment assemblies with a blower

WARNING - Install blower no less than 1 foot (305mm) above the maximum water level to prevent water from contacting electrical equipment.

Save These Instructions

Important Safety Instructions

Marking for equipment assemblies

 WARNING
REDUCE THE RISK OF ELECTROCUTION 1. Install at least 5 feet from water using nonmetallic plumbing. 2. Do not install under spa skirt or within an enclosure that would restrict ventilation. 3. If blower is included, install at least 1 foot above maximum water level.
REDUCE THE RISK OF CHILD DROWING 1. Supervise children at all times. 2. Attach spa cover after each use. 3. Install a suction guard with marked flow rate no less than ____ GPM to avoid hair and body entrapment.
REDUCE THE RISK OF OVERHEATING 1. Check with a doctor before use if pregnant, diabetic, in poor health, or under medical care. 2. Exit immediately if uncomfortable, dizzy or sleepy. Spa heat can cause hyperthermia and unconsciousness. 3. Spa heat in conjunction with alcohol, drugs, or medication can cause unconsciousness.
WHEN PREGNANT, soaking in hot water for long periods can harm your fetus. Measure water temperature before entering. 1. Do not enter spa if water is hotter than 100°F (38°C). 2. Do not stay in spa for longer than 10 minutes.

AUDIO COMPONENT WARNINGS

Spas equipped with the Audio system should follow these guidelines for safety:

- 1. CAUTION** - Risk of Electrical Shock - Do not leave compartment door open.
- 2. CAUTION** - Risk of Electrical Shock - Replace components only with identical components.
- 3.** Do not operate the audio controls while inside the spa.
- 4. WARNING - Prevent Electrocutation** - Do not connect any auxiliary components (for example cable, additional speakers, headphones, additional audio/video components, etc.) to the system.
- 5.** These units are not provided with an outdoor antenna; when provided, it should be installed in accordance with Article 810 of the National Electrical Code, ANSI/NFPA 70.
- 6.** Do not service this product yourself as opening or removing covers may expose you to dangerous voltage or other risk of injury. Refer all servicing to qualified service personnel.

KEEP THESE SAFETY INSTRUCTIONS IN A CONVENIENT AND READILY ACCESSIBLE LOCATION!!

Electrical Requirements and Installation

The following information is provided for hooking up electrical supply to your new spa. A qualified, licensed, electrician must perform this work. Failure to follow these instructions will terminate all warranty coverage and can cause serious injury or death.

Codes and Compliance

North American 60 Hz	3X JETS, 2 PUMP	4X/5X/6X JETS 2/3 PUMPS
Voltage	240VAC	240VAC
Max Current Draw	37A	48A
Number of Wires	4	4
GFCI	50A	60A

Your export 50 Hz Artesian spa is preset out of factory to run 230V 3wires 30 amp max input. This product must always be connected to residual current device (RCD) having a trip current of not more than 30mA.

Electrical Wiring

WARNING: Your spa must be wired by a certified electrician and according to these instructions. Failure to do so will terminate all warranties and all listings from the independent listing facility.

- 1) The Island Class Spa requires a 240 VAC dedicated system. The spa must be hard wired to the power supply, with no plug-in connections, extension cords, or sharing of service.
- 2) The spa requires that you run 6 (10 mm²) or 8 (8.4 mm²) AWG copper wire, depending on the GFCI size. Do Not Use Aluminum Wire.
- 3) The power supply must have a suitable Ground Fault Circuit Interrupter (GFCI), according to Section 422-20 of the National Electrical Code, ANSI/NFPA 70-7987 or other national installation requirement with a residual current device (RCD) having a trip current of not more than 30 mA. This could be used as the shut-off switch, which must be installed in plain view of the spa. This electrical service must be readily accessible to the spa occupants, but must not be within 5 feet of the spa.
- 4) Use only non-metallic conduit and fittings when installing power to the spa.
- 5) After your spa has been positioned, route lines through the knockout on the left or right front corner of the spa.

Picture of System Box Terminal Connection for 60Hz

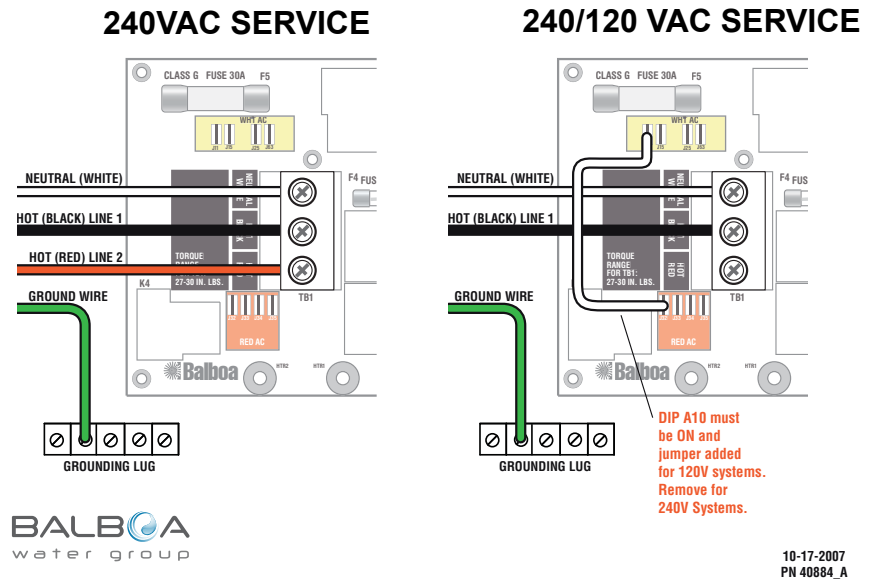

- 6) Connect the power to the spa

Connect each color to its respective terminal block location. The Ground (green) wire must be connected to the grounding terminal which is outside of the System box. The Grounding wire must first enter the system box and then access the grounding terminal via a hole on the side of the box adjacent to the grounding terminal as shown in the picture above.

60 Hz GFCI Wiring Schematic

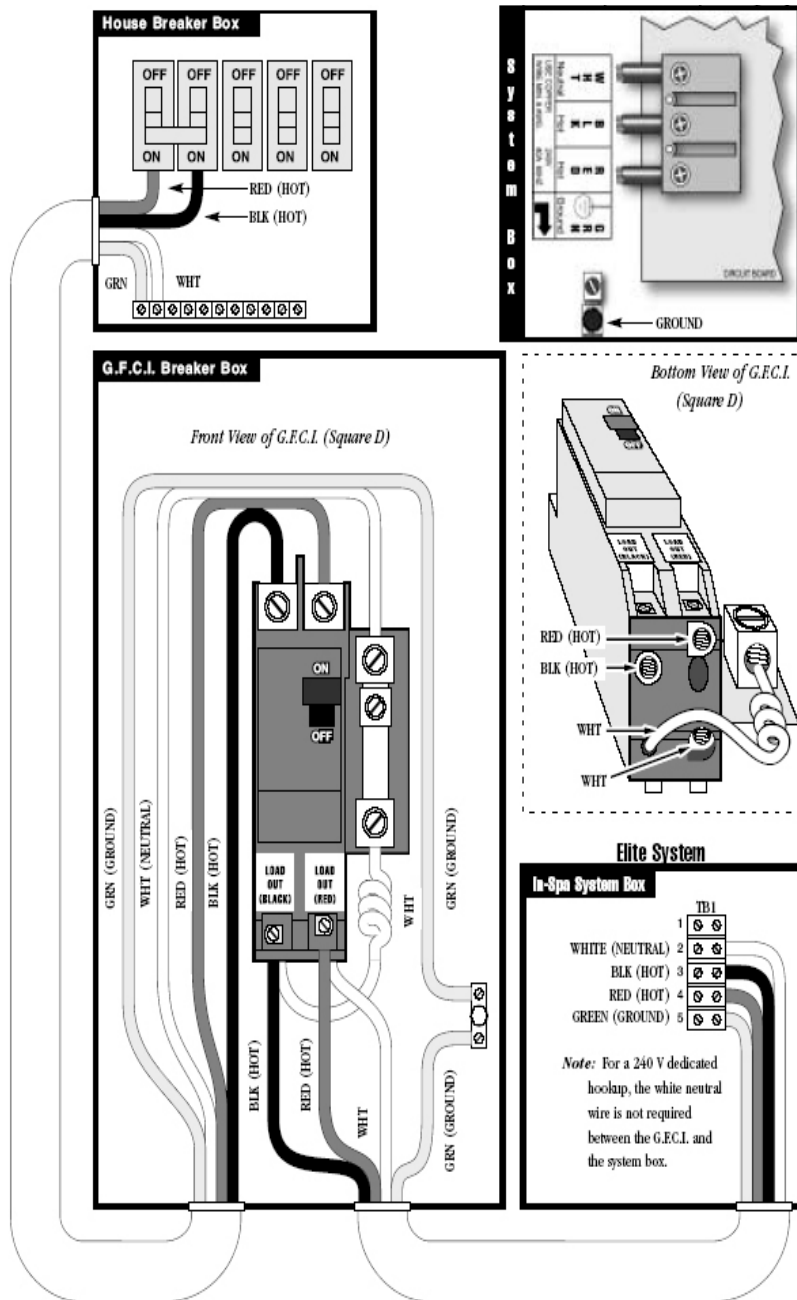

50 Hz Electrical Service Configuration

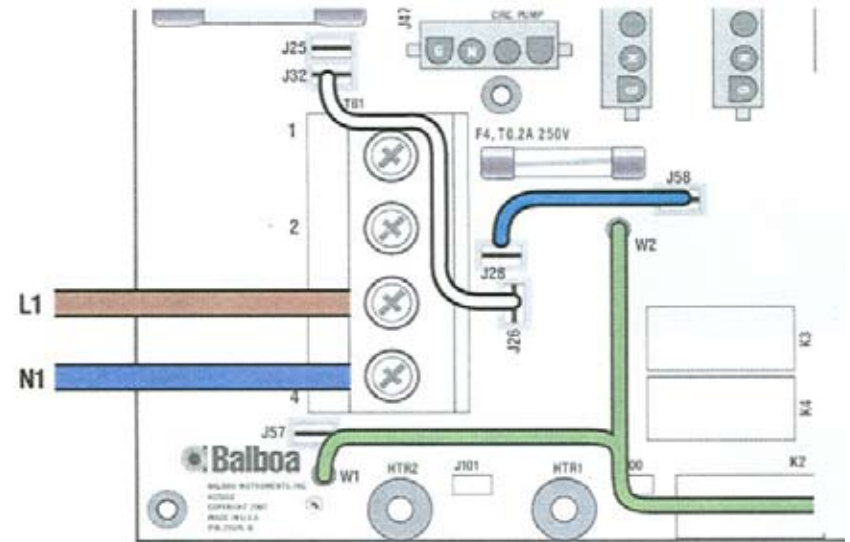

Single Service, TN and TT Electrical Systems

(1 X 16 Amp or 1 X 32 Amp)

3 Wires (1 Line + 1 Neutral + 1 Protective Earth)

Protective Earth wire (Green / Yellow) must be connected to system ground terminal as marked.

This option is configured and shipped as the default.

All equipment (pumps, blower and heater) runs on service line L1

50 Hz Electrical Service Configuration

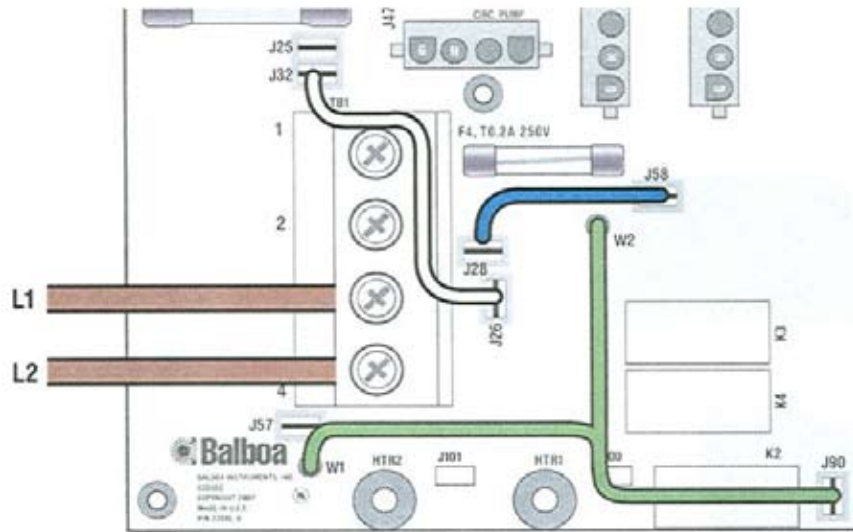

Single Service, IT Electrical System (No Neutral)

Line - Line voltage is 230VAC (1 X 16 Amp or 1 X 32 Amp)

3 Wires (2 Lines + 1 Protective Earth)

Protective Earth wire (Green / Yellow) must be connected to system ground terminal as marked.

All equipment (pumps, blower and heater) runs on service line L1 with L2 acting as the return.

50 Hz Electrical Service Configuration

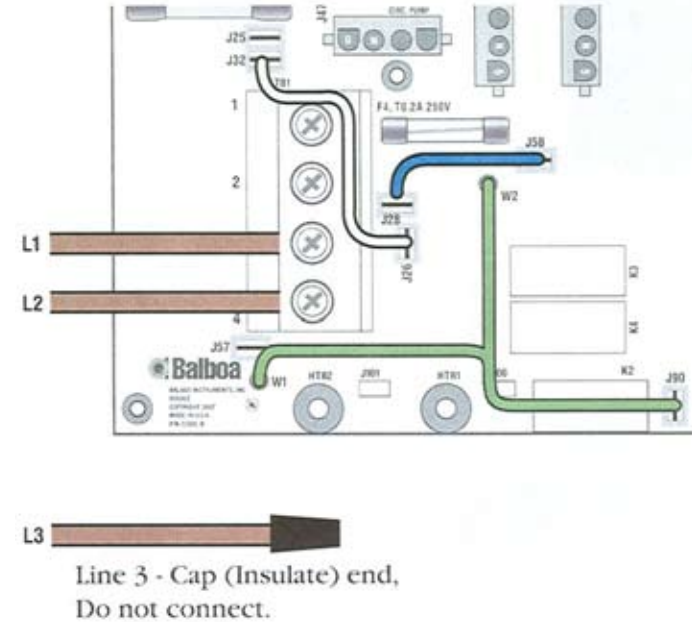

3 Phase Service, IT Electrical System (No Neutral)

Line - Line voltage is 230VAC

4 Wires (3 Lines + 1 Protective Earth)

Protective Earth wire (Green / Yellow) must be connected to system ground terminal as marked.

All equipment (pumps, blower and heater) runs on service line L1 with L2 acting as the return.

Spa Start-up

Please read each step of the Start-up section prior to doing the step.

Selecting a Location

In preparation for installing your new Island spa, you should ensure that your chosen location meets some minimum guidelines:

- 1) Place your spa on a surface that is large enough for the entire spa to fit. Consider the space needed to easily access equipment compartments and circuit breakers. Remember, all electronics must be kept dry.
- 2) The spa must be on a solid, level foundation. Recommended: 4-inch cement slab that has cured for at least 72 hours. Your warranty will be voided if the spa is not properly installed. Structural damage due to an improper foundation is not covered under warranty.
- 3) To avoid potential water damage to the skirt and frame, your spa should be placed on a site where it will not be in the way of water sprinklers.
- 4) OUTDOOR SPAS: Consider building codes, electrical and plumbing codes, desired proximity to house, wind and sun exposure, location of trees (falling leaves, shade), dressing area, landscaping and lighting when selecting a location.
- 5) INDOOR SPAS: Floor surface must have traction to prevent slipping when wet. A floor drain is optimum. As room humidity will increase because of the spa, provide ample ventilation to prevent dry rot, mildew and mold. Use materials that will withstand humidity. There may be a need for cross-ventilation fans and/or dehumidifiers. The spa chemicals may corrode some household metals. Provide ample room if servicing should be needed. Strong foundational support is vital, particularly if a second-story site is selected.
- 6) Ensure the equipment compartment is in a location where it will not be damaged by water drainage. Cover the equipment compartment with a heavy screen if rodents are a problem. Damage due to rodents is not covered under warranty.

7) Have the spa deck installed by a knowledgeable contractor to ensure proper support.

8) If the spa is placed on the ground, even for a short period of time, it must be supported by stones that are at least 2 inches thick and 12 inches square. A solid foundation is recommended as soon as possible.

Inspection

You will want to inspect your spa, prior to filling it up with water. Look for and remove any debris in the spa tub and in the filter. Verify that pump plugs are installed on the pumps and the pump unions are tight.

Filling the Spa with Water

NOTE: DO NOT fill your spa with hot water straight out of your water heater or tap. This water may be as hot as 180 degrees F and will cause damage to the surface and plumbing of the spa. This will void your warranty. Level the spa before filling.

- 1) Prepare to fill the tub by removing all debris.
- 2) Remove the filters from your spa (see Removing, Installing and Cleaning Filters, page 29.)
- 3) Insert the hose in the area where the filter was located as shown in the picture below.



Spa Start-up

Filling the Spa with Water

4) Fill the spa to the bottom of the pillows.

Note: DO NOT OVER-FILL YOUR TUB!

5) With the front panel off, verify there are no leaks at the pump union.

Note: Pump unions can become loose during shipping. Verify that there are no leaks during filling of the spa.

6) Replace both filters.

Turning the Power On

Turn the power to the spa on at the main circuit breaker. Verify that your spa has no error codes. (See page 33) Verify that there is good water circulation in the spa. The pump will initially come on for 5 minutes and cycle through each pump for one minute on each pump at start up.

Verifying Water Circulation

1) Open all the jets.

2) Press the Jets 1/2/3 button to turn the pumps on or off.

3) Make sure each seat has water flow.

Testing the GFCI Breaker

NOTE: The electrical service panel for your spa should be equipped with a GFCI breaker. To avoid the risk of electrical shock, perform the following safety test before each use of your spa.

1) Make sure the power is turned on at the electrical service panel.

2) Turn on the GFCI breaker. If the breaker stays on, it is functioning properly.

Danger Risk of Electrical Shock

If the GFCI breaker fails to operate as described, there is a possibility of an electric shock if the spa is used. Shut off the power at the main electrical service panel until the source of the problem has been identified and corrected by a licensed electrician or qualified spa technician.



Spa Start-up

Turning on the Spa for the first time.

NOTE: When power is turned on, your spa will automatically start out in priming mode for approximately 2 minutes indicated by “Pr” on the topside control. During this time no components are powered. At the end of the two minute period the low speed pump will be activated for 30 seconds followed by all of the pumps being activated on high speed for another 30 seconds. Once the high speed pump(s) have turned off a temperature reading will be taken. This takes about 2 minutes for the heater to correctly display a temperature reading to the topside control.

Adjust your temperature by pressing the “Warm”  or

“Cool”  button on your touch pad until the

desired temperature is displayed. This setting will allow your spa to heat to the set temperature.

CAUTION: If water is not noticeably coming from your spa jets during the automatic purge, turn on the high speed pump. If water is still not coming from the jets, the pump needs to be manually primed, following the steps below.

Priming the Pump

- 1) Turn off power at electrical service panel.
- 2) Locate and loosen the pump by turning it counterclockwise one half of one turn.
- 3) Allow air to escape from the fitting. When a steady stream of water flows from the pump plug, close it by turning it clockwise until tight.
- 4) Turn on power at electrical service panel.
- 5) Check once more to make sure that water is flowing from the jets during auto purge. If so, continue. If no water is coming from your spa jets, please call your Island Spas dealer for further assistance.

Water Preparation

NOTE: Before putting your new spa into operation, understand that preparing your new water is an important part of maintenance. Failure to properly prepare your water can result in substantially decreasing the life of the components and may void your warranty in severe cases. Your Island Spas dealer should have a start-up and maintenance kit available for you when you purchase your spa.

Topside Controller Instructions

Initial Start up / Setting the Time of Day





Topside control for Island models

After the spa has been powered up and the topside controller is finished displaying “Pr”, the user may control the various pumps, lights, temperature of the water, filter cycles, and choose between different modes of operation from this topside controller.

Setting the Time of Day

When the spa is first powered up, the words “SET TIME” will flash on the display to set the time, press “Time”,

then “Mode” , then “Warm”  or “Cool” .

After “Warm”  or “Cool”  is pressed once, the time

will begin changing in one-minute increments.

Press “Warm”  or “Cool”  to stop the time

from changing. Press “Time”  to enter your correct time into the system.



Light/Mode/Jets

Light

Press the “Light”  button to turn the light on and off.

If left on, the light automatically turns off after 4 hours.

Mode

The mode is changed by pressing “Warm”  or “Cool” 
down arrow then the Mode key. 

Standard Mode is programmed to maintain the desired temperature. Note that the last measured spa temperature is current only when the pump has been running for at least 1 minute. “St” will be displayed momentarily when you switch into Standard Mode.

Economy Mode heats the spa to the set temperature only during filter cycles. “Ec” will display solid when temperature is not current, and will alternate when temperature is current.

Sleep Mode heats the spa to within 20°F/10°C of the set temperature.

Jets

Touch the “Jets 1”  “Jets 2”  (optional)

or “Jets 3”  (optional) button

once to activate the respective pump and its jets. Touch the respective “Jets” button again to turn off the pump. If left running, the pumps will automatically turn off after 15 minutes.

Topside Controller Instructions

Preset Filter Cycles/ Optional Filter Cycles

Preset Filter Cycles

The first filter cycle is automatically activated at 8:00 am and operates the low speed of pump one* (or the circulation pump if spa is equipped) until 10:00 am.



The second filter cycle is automatically activated at 8:00 p.m. and operated at the low speed of pump 1 until 10:00 p.m.

The low speed of pump one and the ozone generator will run during filtration. At the start of each filter cycle, the therapy pumps will run on high speed for the first five minutes.

(*) - Spa equipped with circulation pump is preset to run 24 hours from the factory, please see the next section to adjust the duration of the circulation pump cycle.

Optional Filter Cycles (Summer Mode)

During the warm summer months it is advisable to lower the set temp to 85° F or less, to reduce the filter cycle circulation, and to set the spa in “economy mode”.

While you are not required to set the filter cycles, if you want to change them press “Time”  then “Mode”, 

“Mode” within three seconds.

“SET START FILTER 1” (AM cycle) will appear on the display.

Press “Warm”  or “Cool”  to reset the filter start time.

Optional Filter Cycles (Summer Mode) cont...

Press "Mode"  to see "SET STOP FILTER 1" and adjust the time with "Warm"  or "Cool"  as done above.

Press "Mode"  to see "SET START FILTER 2" (PM cycle) and proceed as above.



Pressing "Mode"  will enter the new filter cycle times into the system and display the current water temperature.

Temp/Set (80°F - 104°F / 26°C - 40°C) Freeze Protection



Temp/Set (80°F - 104°F / 26°C - 40°C)

The start-up temperature is set to 100°F/37°C. The Last measured temperature is constantly displayed on the LCD.

NOTE: The last measured spa temperature displayed is current only when the pump has been running for at least 1 minute.

To display the set temperature, press the "Cool"  or "Warm"  pad once.

To change the set temperature, press the pad a second time before the LCD stops flashing.

Each press of the "Cool"  or "Warm"  pad will continue to either lower or raise the set temperature respectively. After three seconds, the LCD will stop flashing and display the current spa temperature.

Freeze Protection

If the temperature sensors detect a drop to below 44°F/6.7°C within the heater, the pump will automatically activate to provide freeze protection. The equipment stays on until 4 minutes after the sensors detect that the spa temperature has risen to 45°F/7.2°C or higher. In cold climates, an additional freeze sensor may be added to protect against freeze conditions that may not be sensed by the standard sensors. Aux freeze sensor protection acts similarly except with the temperature thresholds determined by the switch and without a 4-minute delay in turnoff. See your dealer for details.



ML700 Quick Reference Guide*

Initial Start Up



When your spa is first acutated it will go into priming mode (after displaying some configuration information). Please see the M-7 Installation instruction manual for complete instructions Power up and pump priming.

The Priming mode will last for up to 4 minutes and then the spa will begin to heat and maintain the water temperature in the Standard mode. You can exit Priming mode early by pressing

"Warm"  or "Cool" .

Time

When time hasn't been programmed, the "Time"  icon flashes.

(time settings on EL1000 and some EL 2000 systems are not preserved in the event of power loss, time will have to be reprogrammed upon each power up.)

ML700 Quick Reference Guide

Setting the Time

Once the spa has been properly connected the first time (every power up on the EL1000 and some EL2000 systems), notice the “Time” icon appearing on the screen.

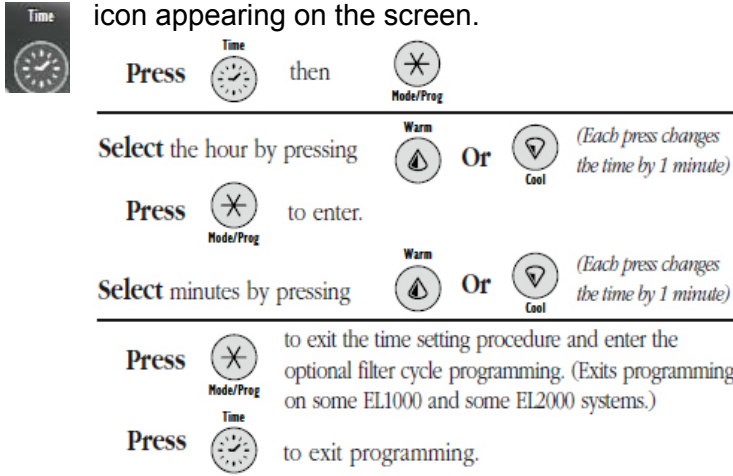

This button is used to switch between standard, economy, and sleep modes, press “Mode/Prog”



to enter mode programming, press “Cool” to cycle through to desired mode (LCD flashes until confirmed)



then press “Mode/Prog” to confirm selection.

Standard Mode maintains the desired temperature Note that the last measured spa temperature displayed is current only when the pump has been running for at least 1 minute, the “STANDARD” icon will display until the mode is changed.

Economy Mode heats the spa to set temperature only during filter cycles. The “ECONOMY” icon will display until mode is changed. Pressing “jets1” while in economy mode puts the spa in Standard -In-Economy mode, which operates the same as Standard mod, then reverts to economy Mode automatically after 1 hour. Both the “Standard” and Economy” icons display in this mode.

ML700 Quick Reference Guide

During this time, a press of the “Mode/Prog” button



will revert to Economy Mode immediately.

Sleep Mode heats the spa to within 20 degrees F (11degrees C) of the set temperature only during filter cycles, the “Sleep” icon will display until mode is changed.

Standby Mode



will turn off all spa functions temporarily. This is helpful when changing a filter. Pressing any button resets the spa.

Locking the Panel

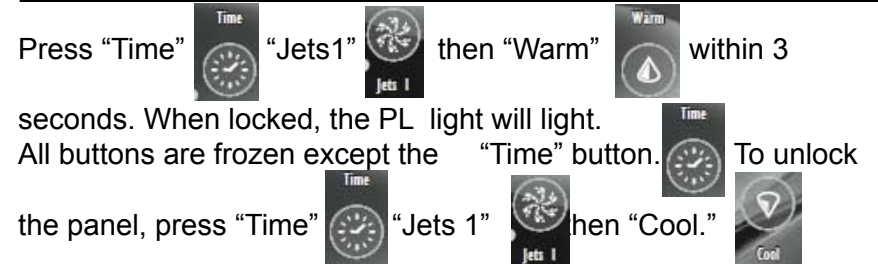

Locking the Set Temperature

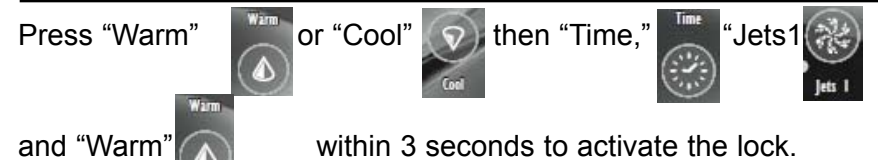

The TL “light will light when the set temperature is locked.

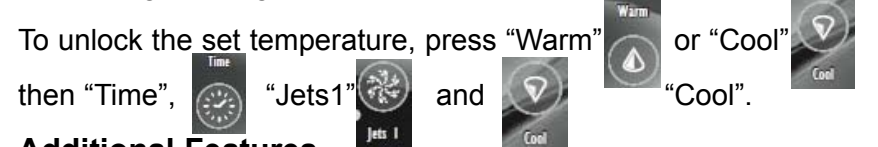

Additional Features

Refer to your User Guide for additional details and features that are available with your ML700 panel and EL/GL Series system. *Spa equipped w/pulsating wave option

Diagnostic Messages

--	Temperature unknown. After the pump has been running for 2 minutes, the temperature will be displayed
OHH	“Overheat” - The spa has shut down. One of the sensors has detected 118°F/48°C at the heater. Do Not Enter The Water. Remove the spa cover and allow water to cool. Once the heater has cooled, reset by pushing any button. If spa does not reset, shut off the power to the spa and call your dealer or service organization.
OHS	“Overheat” - The spa has shut down. One of the sensors has detected that the spa water is 110°F/43°C. Do Not Enter The Water. Remove the spa cover and allow water to cool. At 107°F/42°C, the spa should automatically reset. If spa does not reset, shut off the power to the spa and call your dealer or service organization
ICE	“Ice” - Potential freeze condition No action required. The pump and blower will automatically activate regardless of spa status.
SnA	Spa is shut down. The sensor that is plugged into the Sensor “A” jack is not working. If the problem persists, contact your dealer or service organization. (May appear temporarily in an overheat situation and disappear when the heater cools.)
SnB	Spa is shut down. The sensor that is plugged into the Sensor “B” jack is not working. If the problem persists, contact your dealer or service organization. (May appear temporarily in an overheat situation and disappear when the heater cools.)

Diagnostic Messages

SnS	Sensors are out of balance. If alternating with spa temperature, it may just be a temporary condition. If flashing by itself, spa is shut down. If the problem persists, contact your dealer or service organization.
HFL	A significant difference between temperature sensors has been detected. This could indicate a flow problem. Check water level in spa. Refill if necessary. If the water level is okay, make sure the pumps have been primed. If problem persists, contact your dealer or service organization.
LF	Persistent low flow problems. (Displays on the fifth occurrence of “ HFL ” message within 24 hours.) Heater is shut down, but other spa functions continue to run normally. Follow action required for “ HFL ” message. Heating capability of the spa will not reset automatically; you may press any button to reset.
dr	Possible inadequate water, poor flow, or air bubbles in detected in the heater. Spa is shut down for 15 minutes. Check water level in spa. Refill if necessary. If water level is okay, make sure the pumps have been primed. Press any button to reset, or this message will automatically reset within 15 minutes. If problem persists, contact your dealer or service organization.
dry	Inadequate water detected in heater. Check water level in spa. Refill if necessary. If water level is okay, make sure the pumps have been primed. Press any button to reset, or this message will automatically reset within 15 minutes. If problem persists, contact your dealer or service organization.

Maintaining Your Spa

Draining Your Spa

Your spa needs to be drained, cleaned, waxed, and refilled about every six months. More frequent water changes may be necessary if bather load is heavy. A hose bib has been provided below the left side of your front access panel, to assist you in draining your spa.

1) Turn off the power to your spa. If you fail to turn the power off, vital components could be damaged. Do not leave an empty spa exposed for long periods of time in hot, sunny weather.

Valve Knob



2) Attach your garden hose to the hose bib.

Hose Bib



3) Place the other end of the hose in an area that will accept the water capacity of your spa.

4) Open the hose bib by turning the valve knob counter-clockwise to the full stop position.

5) Check the garden hose end to see if water is flowing. If water is not flowing, check the hose for kinks. Also check to see if valve is in the full open position.

CAUTION: The chemical content and temperature of the water will cause damage to certain vegetation. We do not recommend that you drain your spa onto plants or lawns. If you choose to do this, please remove your spa cover and allow spa to cool for a minimum of 24 hours with the spa turned off.

Pillow Care

Remove and clean the pillows with soapy water and a soft cloth when needed. Use a vinyl conditioner once a month. Remove pillows when doing chemical shock treatment.

Jet Care

We recommend that you clean your jets when you drain your spa.

1) Spray jet inserts with a mixture of 1 part vinegar to two parts warm water and let soak for 10 - 15 minutes. Periodically rotate the spinner nozzle to break up residue in the jets.



2) Rinse the jet inserts with a standard garden hose



Maintaining Your Spa

Removing, Installing and Cleaning Filters

These are the steps needed to successfully replace your filters. You should replace your disposable spa filters and clean your non disposable filters every four months.

- 1) Turn off all power to your spa and remove the filter lid by lifting it out towards you.
- 2) Turn the filter counterclockwise and remove it from the filter well.
- 3) Dispose of the used filter.
- 4) To replace, set screen back into its place and turn clockwise to fasten. DO NOT over-tighten.
- 5) Place the new filter into position and turn clockwise to fasten. DO NOT over-tighten.
- 6) We recommend the use of a quality filter soak product. Please contact your dealer to purchase all your spa care products.



WARNING: Power to your spa must be turned off prior to removing your filters. The suction at the filter is extremely strong and can cause injury if there is no filter. NEVER run your spa without the filters properly installed. Injury to person and damage to the equipment can occur. Any damage to equipment due to this circumstance will not be covered under warranty.

Winterizing Your Spa

It is not recommended that you drain your spa completely during freezing conditions. We recommend that you leave your spa full of water with the power on to keep the tub from freezing. If you decide to drain your spa during freezing conditions, contact your dealer for help. Contact your Island Spas dealer before refilling a drained spa in freezing temperature.

WARNING: Damage to your spa caused by freezing is NOT covered under warranty. Please contact your local Island Spas dealer to assist you in winterizing your spa.

Replacing the Light Bulb

- 1) Turn off the power at the main electrical service panel.
- 2) Remove front access panel.
- 3) Locate and remove the reflector by turning it counterclockwise until free from wall fitting.
- 4) Remove the bulb from the holder.
- 5) Replace with new bulb. Your Island Spas dealer has these bulbs in stock.
- 6) Replace the reflector by screwing it clockwise back onto the wall fitting.
- 7) Replace the front panel.
- 8) Turn power on at the main electrical service panel.

NOTE: The spa light bulb is not covered under warranty. Also, any servicing of any multiple light systems should be done by an authorized service center.

Maintaining Your Spa

Spa Cabinet Care

Your spa comes standard with a PermaWood, or faux wood, cabinet. This cabinet requires no maintenance. You may wish to clean the cabinet with mild soap and water from time to time. If you elected to purchase your spa with a wood cabinet, this cabinet is stained and sealed with an oil based acrylic stain. The stain is formulated especially for spa cabinet and deck applications and is resistant to ultraviolet light damage caused by sun rays. It is also resistant to fungus and insect damage. Your Island Spas dealer carries this type of stain for your convenience, so call your dealer when you're ready to re-stain your cabinet. You should re-seal your wood cabinet at least once a year, or more frequently depending on your environmental conditions.

- 1) Gently wash the cabinet with mild soap and water and allow to dry completely.
- 2) Moisten a rag with the stain you have purchased from your Island Spas dealer.
- 3) Apply the stain on the entire cabinet surface, wiping off any excess stain as you are applying.
- 4) Allow stain to dry for a minimum of 24 hours before getting the cabinet wet.

NOTE: Do not apply any solid type finish such as shellac or varnish. After weathering, these types of finishes will crack and/or turn yellow. To refinish the wood, you will need to completely strip the finish before applying the new one. Use only the stain recommended by your Island Spas dealer for refinishing your spa.

Cleaning Your Spa Interior

It is important to clean the interior of your spa every time it is drained to help preserve the sheen of your spa's surface. However, it is important that you do not use any abrasive cleaners or strong chemicals. Your Island Spas authorized dealer will be able to supply you with the proper cleaning solution for your spa. After cleaning, make sure all residues

are removed prior to filling the spa. This will help prevent sudsing and improper chemical balance.

Cover Care

Cleaning of your spa cover is an important part of routine maintenance. Dirt acts as an abrasive to the vinyl topcoat, and can also cause wear to folds, seams and stitching. Mildew growing on damp, dirty vinyl will begin to actually rot in the fabric, accelerating failure.

Follow this simple routine for cleaning, prior to application of vinyl

- 1) Rinse with cool water using a garden hose.
- 2) Spray with a gentle, non-foaming cleaner and wipe clean. Never use laundry detergent, abrasives, alcohols, dish soaps or harsh cleaners. These can actually remove some of the topcoat and cause premature vinyl failure.
- 3) For stubborn dirt, use a non-abrasive sponge.
- 4) Rinse again thoroughly with water and allow to dry.
- 5) Repeat monthly, or as needed.

Your vinyl cover is affected by the UV in sunlight. Periodic protection with a liquid protectant will extend the life of your spa cover. The wrong kind of protectant can be more harmful than no protectant at all. Keep any product away from your spa that is labeled "flammable," that contains any type of oil, or that leaves a waxy coating on your cover.

Never stand or sit on the cover and never drag it over abrasive surfaces. Lift cover only by the handles provided.

Maintaining Your Spa

Chemical Treatment of Water

Water from your tap is fine for showers, bathing and drinking. However, in a contained recirculating system such as in a spa, water must be treated with chemicals. The main purpose of chemical treatment is to keep the water sanitary and to maintain a specific balance of the water. Proper balance ensures that the water will not cause irritation to the users or harm the spa's components. Chemical treatment does have its limitations. When water evaporates, chemical residues are left behind. As the levels of the residues combine with other types of residue, such as body oil and detergents, your water becomes increasingly difficult to maintain. Because of this residual effect, at some point it becomes easier and more cost-effective to drain, clean and refill your spa with new water. We recommend that the water be changed at least every six months. At this time you should also clean or replace your filters. If your spa has a frequent and/or heavy bather load, it may be necessary to drain and fill your spa more often. Refer to the section titled "Draining your spa" for instructions (page 27).

WARNING: Spa damage due to improper chemicals use is not covered under warranty.

Water Chemistry

CAUTION: The chemicals used to maintain the pH balance of the water and to sanitize the water can be dangerous. Always follow these basic guidelines when handling the chemicals

1. Always read and follow the directions on the label, unless directed otherwise.
2. Never mix different chemicals.
3. Do not exceed the recommended amounts of chemicals—follow the directions on the label.
4. Keep all chemicals out of the reach of children and pets.
5. Keep containers closed tightly when not in use.
6. Never add water to the chemicals—always add the chemicals to the water as directed.
7. Always store chemicals in a cool, dry place.

NOTE: Consult your dealer on local water chemicals as its varies from location to location.

Water Treatment Glossary

1 - Total Alkalinity: Total Alkalinity measures the water's ability to resist fluctuations in the pH level. It is measured in ppm (parts per million) ranging from 0 - 400 or up. The optimum range for your spa water is between 80 and 140. This can easily be measured with 3- or 5-way test strips. With low alkalinity the pH level will be prone to dramatic fluctuations. With high alkalinity the pH becomes increasingly difficult to adjust.

2 - pH (potential hydrogen): The pH is used as a measurement of the active acidity, the concentration of active hydrogen molecules in the water. pH is measured on a scale from 1 to 14, the lower numbers indicating a greater concentration of active hydrogen. While 7, halfway between base and acid is neutral, the optimum level of acidity for a spa is between 7.2 and 7.8.